

user manual

HydroMinder (Car Wash)

index

1.00	introduction	page
	package contents	2
	safety precautions	2
2.00	installation	
	installation/operation	3
3.00	tip/ULD chart	3
4.00	ULD identification	4
5.00	parts list	5
	parts list / diagrams	
6.00	troubleshooting	6

introduction

package contents:

1. Proportioner with U-clamp for mounting
2. Float with chain
3. Inlet tube, 1/4" x 7' with weight and footvalve
4. Discharge tube 2ft.
5. Metering tip kit or ULD pack
6. Instruction sheet

safety precautions



WARNING please read precautions thoroughly before operation. Unit must be installed in accordance with local regulations.

For Units installed in Australia:

**THIS APPARATUS MUST BE INSTALLED IN ACCORDANCE WITH THE REQUIREMENTS OF THE PLUMBING CODE OF AUSTRALIA (PCA)
AS/NZS 3500.1**

THANK YOU FOR YOUR INTEREST IN OUR PRODUCTS

Please use this equipment carefully and observe all warnings and cautions.

*****NOTE*****

WEAR	protective clothing and eyewear when dispensing chemicals or other materials or when working in the vicinity of all chemicals, filling or emptying equipment, or changing metering tips.
ALWAYS	observe safety and handling instructions of the chemical manufacturer. direct discharge away from you or other persons or into approved containers. dispense cleaners and chemicals in accordance with manufacturer's instructions. Exercise CAUTION when maintaining your equipment. reassemble equipment according to instruction procedures. Be sure all components are firmly screwed or latched into position.
KEEP	equipment clean to maintain proper operation.
ATTACH	only to water tap outlets (20 PSI dynamic Min., 80 PSI Maxi. and Max. water temperature 120° F).
NOTE	if the unit is used to fill a sink, or the discharge hose can be placed into a sink. The unit must be mounted so that the bottom of the cabinet is above the overflow rim of the sink.

installation / maintenance

1. Mount the unit in a level position on the side of a reservoir. The U-clamp may be repositioned or removed as necessary.
2. Install a minimum 3/8" ID water hose between the inlet threads and the water spigot. Minimum water pressure required to properly operate the proportioner is 20 PSI dynamic.
3. Attach the end of the discharge tube with the clamp and flooding ring to the discharge barb on the eductor.
4. Insert the foot valve end of the suction tube into the concentrate container. (The level of the concentrate must be below the level of the eductor, or the proportioner will continue to siphon concentrate after it is turned "off".)
REMEMBER TO CHECK FOOT STRAINERS PERIODICALLY FOR CLOGGING: CLEAN IF NECESSARY
5. Select a push-in metering tip or ULD. Install push-in metering tip it into the suction stub on the eductor body. Install ULD into inlet of eductor body.
6. Slide the open end of the suction tube over the suction stub.
7. Adjust the bead chain length to position the float at the desired level of solution. To prevent foaming, be certain that the solution level will always be above the point of discharge. Be sure float mechanism is not hampered by water turbulence caused by discharging solution. It may be necessary to baffle the float from the discharge in order for the unit to work properly.

operation

1. Connect opposite end of water inlet hose to water supply. Turn on water supply.
2. Prime the system by activating the water valve by pulling down on the yoke.
 NOTE: In order to fully prime a ULD system, continue activating the water valve for 30 seconds after chemical has reached the ULD inlet. There may be some water discharge from the eductor vents until the air is purged.

tip/uld chart

Metering Tip Selection:

The final concentration of the dispensed solution is related to both the size of the metering tip opening and the viscosity of the liquid being siphoned. For water-thin products, the chart at right can be used as a guideline. If product is noticeably thicker than water, consult the Measurement of Concentration Procedure below to achieve your desired water-to-product ratio. Because dilution can vary with water temperature and pressure, actual dilution achieved can only be ascertained by using the Measurement of Concentration Procedure. The clear, undrilled tip is provided to permit drilling to size not listed should you need a dilution ratio that falls between standard tip sizes.

NOTE: A 5 GPM eductor is blue. Refer to parts diagram if unfamiliar with names of system components.

Measurement of Concentration:

You can determine the dispensed water-to-product ratio for any metering tip size and product viscosity. All that is required is to operate the primed dispenser for a minute or so and note two things: the amount of dispensed solution, and the amount of concentrate used in preparation of the solution dispensed. The water-to-product ratio is then calculated as follows:

$$\text{Dilution Ratio (X:1) where X} = \frac{\text{Amount of Mixed Solution} - \text{Amount Concentrate Drawn}}{\text{Amount of Concentrate Drawn}}$$

Dilution Ratio, then, equals X parts water to one part concentrate (X:1). If the test does not yield the desired ratio, choose a different tip and repeat the test. Alternative methods to this test are 1) pH (using litmus paper), and 2) titration. Contact your concentrate supplier for further information on these alternative methods and the materials required to perform them.

Tip/ULD Color	Tip or ULD?	Approximate Dilutions at 40 psi		
		Dilution Ratio (5 GPM Eductor with 1 cP viscosity chemical (water-thin))	Dilution Ratio (5 GPM Eductor with 100 cP viscosity chemical)	Dilution Ratio (5 GPM Eductor with 200 cP viscosity chemical)
Grey	Tip	7:1	35:1	34:1
Black	Tip	8:1	35:1	35:1
Beige	Tip	12:1	37:1	38:1
Red	Tip	18:1	42:1	45:1
White	Tip	30:1	49:1	55:1
Blue	Tip	33:1	53:1	62:1
Lime	Tip	36:1	58:1	64:1
Tan	Tip	45:1	64:1	77:1
Light Blue	Tip	55:1	88:1	95:1
Green	Tip	70:1	97:1	110:1
Orange	Tip	85:1	118:1	134:1
Brown	Tip	110:1	136:1	168:1
Dark Blue	Tip	120:1	160:1	200:1
Yellow	Tip	155:1	180:1	210:1
Aqua	Tip	175:1	220:1	260:1
New Red	Tip	225:1	285:1	350:1
Purple	Tip	260:1	350:1	460:1
Light Grey	Tip	350:1	510:1	590:1
New Black	Tip	380:1	650:1	840:1
Pink	Tip	550:1	780:1	960:1
Red One	ULD	300:1	2150:1	2200:1
Dark Blue One	ULD	400:1	4400:1	4700:1
White Two	ULD	500:1		
Light Blue One	ULD	550:1		
Orange One	ULD	600:1		
Yellow One	ULD	800:1		
Purple One	ULD	900:1		
Pink One	ULD	1000:1		
Dark Green One	ULD	1100:1		
Yellow Two	ULD	1200:1		
Purple Two	ULD	1500:1		
Light Blue Five	ULD	1800:1		
Yellow Four	ULD	1900:1		
Purple Four	ULD	2400:1		
Purple Five	ULD	2500:1		

ULD identification

Active disc chart on the side of ULD.

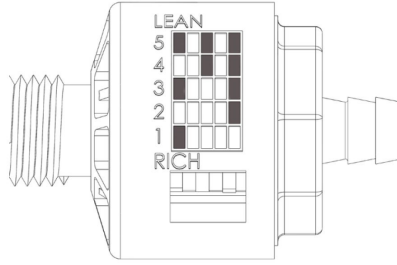

1 ACTIVE

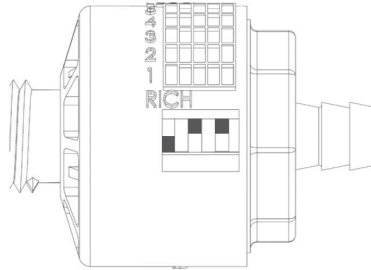

2 ACTIVE

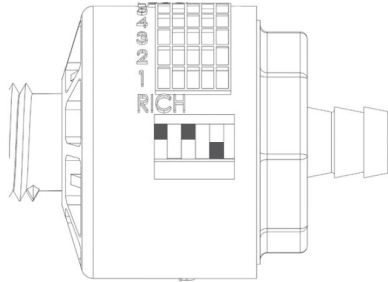

3 ACTIVE

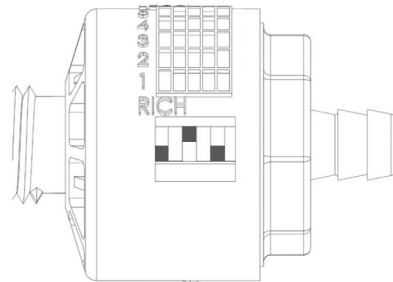

4 ACTIVE

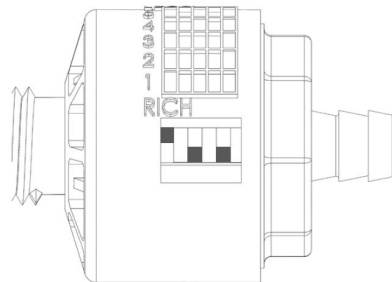

5 ACTIVE

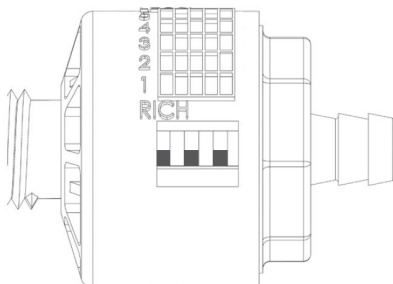

parts list / diagrams

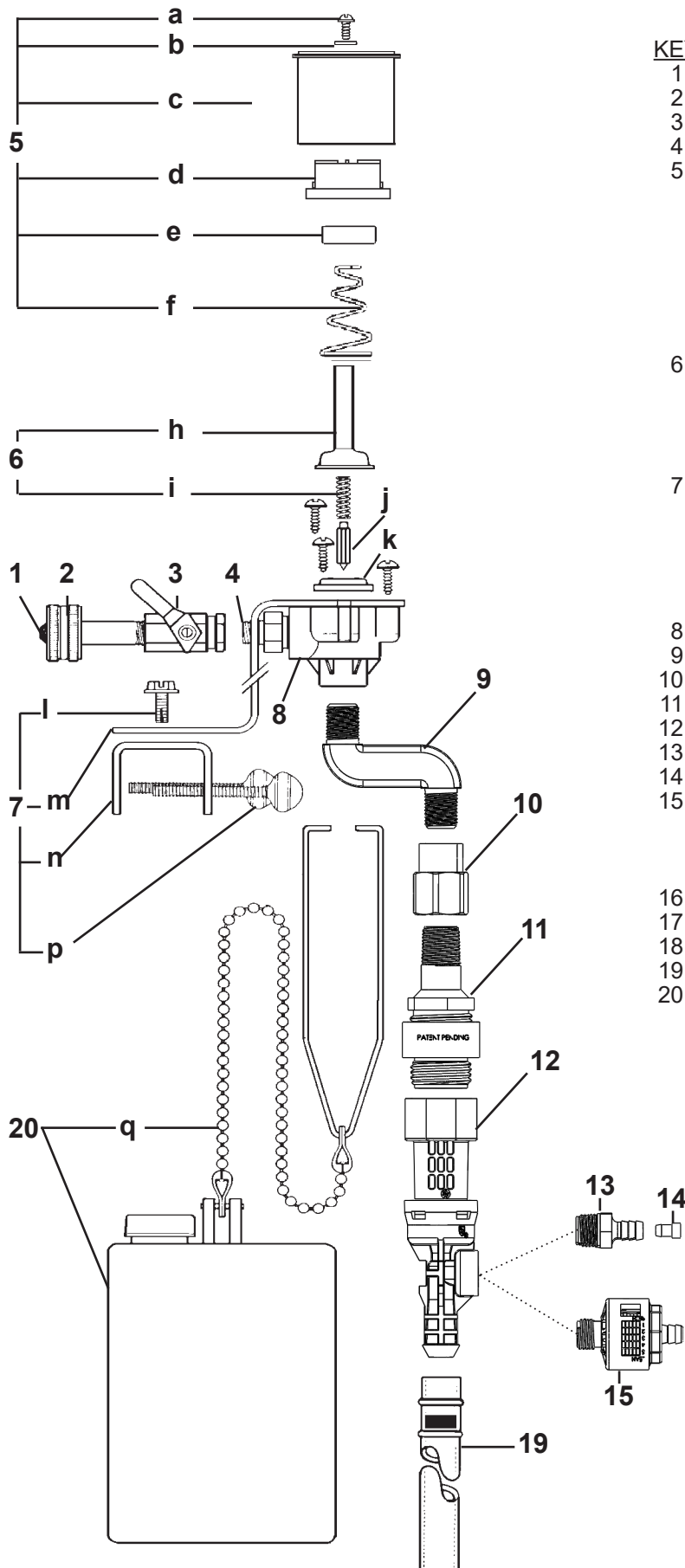

KEY	PART NO.	DESCRIPTION
1	HYD238100	strainer washer
2	HYD5065-K	hose swivel
3	HYD502000	ball valve
4	HYD360900	nipple
5	HYD10080500	magnet parts kit
	a.	screw
	b.	washer
	c.	magnet cover
	d.	magnet cap
	e.	magnet
	f.	magnet spring
	g.	magnet yoke
6	HYD665520	valve parts kit
	h.	valve guide ("bonnet")
	i.	armature spring
	j.	armature
	k.	diaphragm
7	HYD10099886	mounting bracket kit
	l.	screw
	m.	Z bracket
	n.	U clamp
	o.	lockwasher (not shown)
	p.	thumbscrew
8	HYD520000	water valve body
9	HYD10092506	cast manifold
10	HYD622900	coupling
11	HYD10091989	adapter, apad
12	HYD10099885	Kit, 5 gpm e-gap
13	HYD3401-R	hosebarb assembly
14	HYD690014	metering tip (kit)
15	HYD10099869	Kit, ULD 300-550
	HYD10099870	Kit, ULD 600-1000
	HYD10099871	Kit, ULD 1100-1700
	HYD10099872	Kit, ULD 1800-2500
16	HYD500870	tubing, 1/4" x 7'
17	509900	weight
18	HYD10076301	Foot valve, Viton
19	HYD5057-A	discharge tube assembly
20	HYD5043-A	float & chain assembly
	HYD507200	q. bead chain only

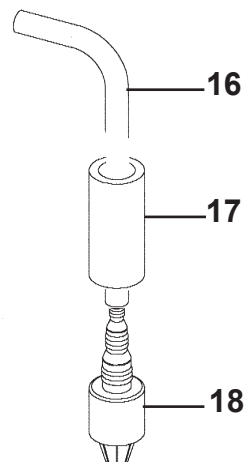

troubleshooting

Problem	Cause	Solution
1. No discharge	a. No water	a. Open water supply
	b. Excessive water pressure	b. Install regulator if water pressure (with water running) exceeds 80 PSI
	c. Clogged water inlet strainer	c. Disconnect inlet water line and clean strainer
	d. Magnetic valve not functioning	d. Install valve parts kit
	e. Eductor clogged	e. Clean* or replace
2. No concentrate draw	a. Metering tip or eductor has scale build-up	a. Clean (descale)* or replace
	b. Low water pressure	b. Minimum 20 PSI (with water running) required to operate unit properly
	c. Discharge tube not in place	c. Push tube firmly onto eductor discharge hose barb, or replace tube
	d. Concentrate container empty	d. Replace with full container
	e. Clogged water inlet strainer	e. Disconnect inlet water line and clean strainer
	f. Incorrect check valve installation	f. See diagram page 3
	g. Air leak in pick-up tube	g. Put clamp on tube or replace tube if brittle
	h. Selector out of position	h. Assure selector is in position desired
3. Excess concentrate draw	a. Metering tip not in place	a. Press correct tip firmly into barb on eductor
4. Failure of unit to turn off	a. Push button stuck	a. Remove button and clean cabinet/button to remove excess dirt lodged in slide recess
	b. Magnet doesn't fully return	b. Make sure magnet moves freely Replace spring if short or weak
	c. Water valve parts dirty or defective	c. Clean or replace with valve parts kit
5. Excess foaming in discharge	a. Air leak in pick-up tube	a. Put clamp on tube or replace tube if brittle

* In hard water areas, scale may form inside the discharge end of the eductor, as well as in other areas of the unit that are exposed to water. This scale may be removed by soaking the eductor in a descaling solution (deliming solution). To remove an eductor located in the cabinet, firmly grasp water valve and unthread eductor. Replace in same manner. Alternatively, a scaled eductor can be cleaned (or kept from scaling) by drawing the descaling solution through the unit. Operate the unit with the suction tube in the descaling solution. Operate the unit until solution is drawn consistently, then flush the unit by drawing clear water through it for a minute. Replace concentrate container and put suction tube into concentrate.